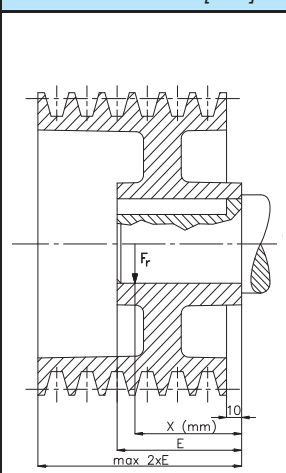

La taglia 200 viene prodotta in 2 esecuzioni: versione MM200 per applicazioni a coppia costante e versione MAG200 con avvolgimenti compensatori per applicazioni con regolazione a potenza costante e/o frequenti sovraccarichi.

Frame 200 is manufactured in 2 different versions: MM200 for constant torque applications and MAG200 with compensator windings for applications with constant power regulation and/or frequent overloads.

Pacco Lenght	Max.potenza eccitazione Max excitation power		Momento d'inerzia Moment of inertia	Dimesioni spazzole Brush dimensions	Cuscinetto lato accoppiamento Drive end bearing		Cuscinetto lato collettore No-drive end bearing	Peso Weight
	MM series	MAG series			Sfere Balls	Rulli Rollers		
	[W]		[Kg m ²]	[mm]				[Kg]
S	1950	1500	1.02	16 x 32 x 50	6315 - 2Z - C3	NU 315 EC	6313 - 2Z - C3	580
M	2300	1730	1.14					625
L	2550	1960	1.26					670
P	2800	2190	1.38					715

Dati ventilazione Ventilation		Elettroventilatore Electrofan		Rumorosità Noise
Potenza Air flow	Prevalenza Pressure	Potenza Power	I a 400 V I at 400V	
[m ³ /h]	[mmH ₂ O]	[kW]	[A]	[dB _A]
2350	170	3	6	87

Carico radiale [daN] ammissibile per una durata teorica del cuscinetto lato accoppiamento di 20.000 ore Admitted radial load [daN] for a theoretic 20.000 hours of the drive end bearing													
	[RPM]	200	400	600	1000	1200	1500	2000	2500	3000	3200	4000	
	6315-2Z-C3	X	Fr [daN]										
0		1523	1171	984	819	749	688	610	556	512	462	-	
35		1465	1127	947	788	720	662	587	535	493	445	-	
70		1412	1086	912	759	694	638	566	515	475	428	-	
105		1362	1047	880	732	669	615	546	497	458	413	-	
140		1315	1012	850	707	647	594	527	480	443	399	-	
NU 315 EC	X	Fr [daN]											
	0	4151	3343	2932	2495	2356	2188	1999	1861	1739	1691	-	
	35	-	3216	2821	2400	2267	2105	1923	1790	1673	1627	-	
	70	-	-	-	2312	2184	2028	1853	1725	1612	1567	-	
	105	-	-	-	-	2107	1956	1788	1664	1555	1512	-	
	140	-	-	-	-	-	-	1727	1607	1502	1460	-	

MM 200 S

	VELOCITA' [RPM] ALLE TENSIONI						P [kW]	I [A]	η [%]	ARMATURA	
	260V	330V	400V	440V	520V	570V				L [mH]	R _{115°} [Ω]
	A	2180								128.5	532
B	1970					127.7	531	92.5	0.26	0.023	
		2540				158.8	515	93.4			
			3110			186.8	497	93.9			
C	1600					105.2	442	91.4	0.39	0.034	
		2060				133.3	436	92.7			
			2530			158.6	424	93.5			
D	1460					94.9	401	91.1	0.47	0.040	
		1880				121.0	397	92.5			
			2300			145.1	389	93.3			
				2540		157.8	383	93.6			
					3030	181.7	372	94.0			
E	1110					70.1	305	88.5	0.76	0.075	
		1440				90.6	303	90.5			
			1780			110.4	301	91.7			
				1970		121.4	299	92.2			
					2350	141.9	293	93.0			
F	810					51.5	231	85.9	1.34	0.130	
		1060				67.2	230	88.4			
			1310			82.7	230	90.1			
				1450		91.5	229	90.8			
					1730	108.7	228	91.8			
G	620					39.2	183	82.3	2.10	0.215	
		820				51.7	183	85.6			
			1020			64.2	183	87.8			
				1130		71.3	183	88.7			
					1360	85.4	182	90.1			
H	500					31.6	152	79.8	3.02	0.300	
		670				42.1	152	83.7			
			830			52.5	152	86.2			
				930		58.4	152	87.3			
					1120	70.2	152	88.9			
I	410					25.7	130	76.2	4.12	0.425	
		550				34.6	130	80.8			
			690			43.5	130	83.9			
				770		48.6	130	85.2			
					940	58.7	130	87.1			
L	340					21.7	114	73.4	5.38	0.549	
		470				29.5	114	78.7			
			590			37.3	114	82.1			
				660		41.7	114	83.5			
					810	50.6	113	85.8			
				900	56.2	113	86.8				

MM 200 M

	VELOCITA' [RPM] ALLE TENSIONI						P [kW]	I [A]	η [%]	ARMATURA	
	260V	330V	400V	440V	520V	570V				L [mH]	R _{115°} [Ω]
	A	1820								128.1	532
		2330				164.2	532	93.5			
			2850			195.9	521	93.9			
B	1650					125.1	522	92.1	0.31	0.025	
		2120				156.8	510	93.3			
			2600			184.8	492	93.9			
				2870		199.4	482	94.1			
C	1330					102.8	435	90.9	0.47	0.038	
		1720				130.5	428	92.4			
			2110			156.6	420	93.3			
				2340		170.2	413	93.6			
					2780	195.3	399	94.1			
D	1210					92.9	395	90.5	0.56	0.045	
		1570				118.5	390	92.1			
			1920			142.7	383	93.1			
				2130		155.8	379	93.5			
					2530	179.8	368	94.0			
E	920					68.6	301	87.6	0.90	0.084	
		1200				88.6	299	89.8			
			1480			108.0	296	91.2			
				1640		118.9	294	91.8			
F	670					50.2	228	84.6	1.61	0.145	
		880				65.7	228	87.5			
			1090			81.0	227	89.3			
				1210		89.5	226	90.1			
					1450	106.3	224	91.3			
G	510					38.0	181	80.6	2.51	0.239	
		680				50.5	181	84.3			
			840			62.8	181	86.7			
				940		69.7	181	87.8			
					1130	83.5	180	89.4			
H	410					30.5	151	77.9	3.61	0.334	
		550				40.9	151	82.2			
			690			51.2	151	85.0			
				770		57.1	150	86.2			
					930	68.6	150	88.0			
I	330					24.6	128	73.8	4.92	0.474	
		450				33.5	128	79.0			
			570			42.3	128	82.3			
				640		47.3	128	83.8			
					780	57.3	128	86.0			
L						63.5	128	87.1	6.43	0.612	
		380				28.4	112	76.6			
			490			36.1	112	80.4			
				550		40.5	112	82.0			
					670	49.3	112	84.5			
				740	54.8	112	85.7				

NOTE:

- a) Avvolgimenti non compensati
- b) I dati riportati fanno riferimento a motori:
 - con ventilazione assistita adossata PVA
 - in servizio continuo CEI S1
 - con alimentazione con fattore di forma = 1
 - con temperatura massima ambiente 40 °C
 - con altitudine s.l.m. max 1000 m

MM 200 L

	VELOCITA' [RPM] ALLE TENSIONI						P [kW]	I [A]	η [%]	ARMATURA	
	260V	330V	400V	440V	520V	570V				L [mH]	R _{115°} [Ω]
A	1560					127.5	532	92.1	0.30	0.024	
		2000				163.8	532	93.2			
			2450			194.8	519	93.9			
				2710		209.8	507	94.1			
B	1410					123.2	517	91.7	0.36	0.028	
		1820				154.7	504	93.0			
			2230			183.5	489	93.8			
				2460		198.4	479	94.1			
					2930	225.1	458	94.4			
C	1140					101.2	431	90.3	0.54	0.042	
		1480				128.6	424	92.0			
			1810			154.4	415	93.0			
				2000		168.3	409	93.4			
					2390	194.2	397	94.0			
					2630	208.7	388	94.3			
D	1040					91.4	391	89.9	0.65	0.049	
		1340				116.7	386	91.6			
			1650			140.7	379	92.7			
				1820		153.8	375	93.2			
					2180	178.4	365	93.9			
					2390	192.5	359	94.1			
E	790					67.3	299	86.7	1.05	0.092	
		1030				87.1	296	89.1			
			1270			106.3	293	90.7			
				1410		117.0	291	91.4			
F	570					49.0	226	83.4	1.86	0.159	
		750				64.5	226	86.5			
			930			79.6	225	88.6			
				1030		88.1	224	89.4			
					1240	104.7	222	90.8			
					1370	114.8	220	91.4			
G	430					36.9	180	78.9	2.91	0.264	
		570				49.2	180	83.0			
			720			61.5	180	85.7			
				800		68.5	179	86.8			
					960	82.0	178	88.6			
					1070	90.4	177	89.4			
H	350					29.5	149	76.0	4.19	0.368	
		460				39.7	149	80.7			
			580			50.0	149	83.8			
				650		55.8	149	85.1			
					790	67.4	149	87.1			
					880	74.5	148	88.1			
I		380				32.4	127	77.2	5.70	0.523	
			480			41.1	127	80.8			
				540		46.1	127	82.4			
					660	56.1	127	84.8			
					730	62.3	127	86.0			
L		320				27.4	111	74.5	7.45	0.675	
			410			35.0	111	78.7			
				460		39.4	111	80.4			
					570	48.1	111	83.1			
					630	53.6	111	84.5			

MM 200 P

	VELOCITA' [RPM] ALLE TENSIONI						P [kW]	I [A]	η [%]	ARMATURA	
	260V	330V	400V	440V	520V	570V				L [mH]	R _{115°} [Ω]
A	1360					127.0	532	91.7	0.35	0.026	
		1750				163.3	532	92.9			
			2140			193.9	517	93.7			
				2370		209.4	506	94.0			
B	1230					121.8	514	91.2	0.42	0.030	
		1590				153.3	501	92.7			
			1950			182.1	486	93.6			
				2160		197.5	478	93.9			
					2570	224.9	458	94.4			
C	1000					100.0	429	89.7	0.62	0.046	
		1290				127.3	421	91.5			
			1580			153.0	413	92.7			
				1750		166.8	407	93.1			
					2090	193.1	396	93.8			
D	900					90.3	389	89.3	0.74	0.054	
		1170				115.4	384	91.2			
			1440			139.3	377	92.4			
				1600		152.4	373	92.9			
					1900	177.1	364	93.6			
					2100	191.6	358	94.0			
E	680					66.2	297	85.7	1.20	0.101	
		890				85.9	295	88.4			
			1110			105.1	292	90.1			
				1230		115.7	289	90.8			
F	490					47.9	224	82.1	2.12	0.174	
		650				63.3	224	85.5			
			810			78.5	224	87.8			
				900		86.8	222	88.7			
					1080	103.5	221	90.2			
					1190	113.5	219	90.9			
G	370					35.8	178	77.3	3.32	0.289	
		500				48.0	178	81.7			
			620			60.3	178	84.6			
				690		67.3	178	85.8			
					840	80.9	177	87.7			
					930	89.2	176	88.7			
H		400				38.7	148	79.2	4.78	0.402	
			510			48.8	148	82.5			
				570		54.7	148	83.9			
					690	66.3	148	86.1			
					760	73.4	148	87.2			
I		330				31.4	126	75.3	6.51	0.572	
			420			40.0	126	79.3			
				470		45.0	126	81.0			
					570	54.9	126	83.7			
					640	61.1	126	84.9			
L			350			34.0	110	77.0	8.50	0.738	
				400		38.3	110	78.9			
					490	47.0	110	81.8			
					550	52.4	110	83.3			

NOTE:

a) Avvolgimenti non compensati

b) I dati riportati fanno riferimento a motori: • con ventilazione assistita adossata PVA • in servizio continuo CEI S1

• con alimentazione con fattore di forma = 1 • con temperatura massima ambiente 40 °C • con altitudine s.l.m. max 1000 m

MAG 200 S

	VELOCITA' [RPM] ALLE TENSIONI						P [kW]	I [A]	η [%]	ARMATURA	
	260V	330V	400V	440V	520V	570V				L [mH]	R _{115°} [Ω]
A	2120						127.7	532	92.2	0.10	0.023
B	1890						125.2	532	90.4	0.12	0.033
		2450					157.2	518	91.9		
			3000				185.7	501	92.7		
C	1540						103.5	443	89.9	0.17	0.043
		2000					132.0	437	91.6		
			2450				157.8	426	92.6		
				2710			171.6	420	92.9		
D	1380						92.2	401	88.4	0.21	0.057
		1800					118.5	397	90.4		
			2210				143.2	391	91.7		
				2450			156.2	385	92.1		
E	1070						68.9	305	86.9	0.33	0.089
		1390					89.4	304	89.2		
			1720				109.4	302	90.7		
				1910			120.5	300	91.3		
F	760						49.5	231	82.5	0.59	0.168
		1000					65.2	230	85.8		
			1250				80.8	230	87.9		
				1390			89.6	229	88.8		
G	590						37.8	183	79.4	0.93	0.255
		780					50.4	183	83.3		
			980				62.9	183	85.9		
				1090			70.0	183	87.0		
H	480						31.0	152	78.5	1.34	0.324
		640					41.5	152	82.6		
			810				51.9	152	85.4		
				900			57.9	152	86.5		
I	400						25.9	130	76.8	1.82	0.413
		540					34.8	130	81.3		
			680				43.8	130	84.3		
				760			48.8	130	85.6		
L	350						22.3	114	75.4	2.38	0.503
		470					30.1	114	80.3		
			590				37.9	114	83.4		
				660			42.4	114	84.8		
				800		51.2	113	86.8			
					890	56.8	113	87.8			

MAG 200 M

	VELOCITA' [RPM] ALLE TENSIONI						P [kW]	I [A]	η [%]	ARMATURA	
	260V	330V	400V	440V	520V	570V				L [mH]	R _{115°} [Ω]
A	1770						127.2	532	91.9	0.10	0.025
		2270					163.4	532	93.0		
			2780				196.2	524	93.6		
B	1580						122.6	524	90.0	0.12	0.036
		2040					154.8	512	91.6		
			2510				183.6	495	92.6		
				2780			198.6	485	93.0		
C	1280						101.2	436	89.3	0.18	0.047
		1670					129.2	429	91.2		
			2050				155.6	421	92.3		
				2270			169.5	415	92.8		
D	1150						90.2	395	87.7	0.22	0.063
		1500					115.9	391	89.9		
			1850				140.6	385	91.3		
				2050			153.9	381	91.9		
E	890						67.3	301	85.9	0.35	0.098
		1160					87.4	299	88.5		
			1430				106.9	297	90.2		
				1590			117.9	295	90.8		
F	630						48.1	228	81.0	0.62	0.185
		830					63.7	228	84.7		
			1040				79.0	227	87.0		
				1150			87.6	226	88.0		
G	480						36.6	181	77.7	0.97	0.281
		640					49.1	181	82.1		
			810				61.5	181	84.9		
				900			68.4	181	86.1		
H	400						30.0	151	76.7	1.40	0.355
		530					40.4	151	81.2		
			670				50.7	151	84.2		
				750			56.6	150	85.5		
I	330						25.0	128	74.9	1.91	0.454
		450					33.8	128	79.8		
			560				42.6	128	83.0		
				630			47.7	128	84.4		
L	350						22.3	114	75.4	2.49	0.553
		470					30.1	114	80.3		
			590				37.9	114	83.4		
				660			42.4	114	84.8		
				800		51.2	113	86.8			
					740	55.6	112	86.9			

NOTE:

a) Avvolgimenti compensati

b) I dati riportati fanno riferimento a motori: • con ventilazione assistita adossata PVA • in servizio continuo CEI S1

• con alimentazione con fattore di forma = 1 • con temperatura massima ambiente 40 °C • con altitudine s.l.m. max 1000 m

MAG 200 L

	VELOCITA' [RPM] ALLE TENSIONI						P [kW]	I [A]	η [%]	ARMATURA	
	260V	330V	400V	440V	520V	570V				L [mH]	R _{115°} [Ω]
A	1510						126.6	532	91.4	0.12	0.028
		1950					162.9	532	92.7		
			2390				195.1	522	93.5		
				2640			210.4	510	93.8		
					3140		237.6	485	94.2		
B	1350						120.5	518	89.4	0.14	0.039
		1750					152.5	506	91.3		
			2150				182.0	492	92.4		
				2380			197.3	483	92.9		
					2840		224.9	462	93.5		
C	1100						99.6	432	88.7	0.21	0.052
		1430					127.2	425	90.7		
			1760				153.3	417	92.0		
				1940			167.5	411	92.5		
					2320		193.9	400	93.3		
D	980						88.6	392	86.9	0.25	0.069
		1280					114.1	387	89.3		
			1580				138.5	381	90.9		
				1760			151.7	377	91.5		
					2100		177.0	368	92.5		
E	750						66.0	299	84.9	0.41	0.108
		990					85.9	297	87.7		
			1230				105.2	294	89.6		
				1360			116.0	292	90.3		
F	530						46.8	226	79.6	0.72	0.202
		710					62.4	226	83.6		
			880				77.5	225	86.1		
				990			86.0	224	87.2		
					1190		102.8	222	88.9		
G	410						35.5	180	76.1	1.13	0.306
		550					47.9	180	80.7		
			690				60.2	180	83.8		
				770			67.2	179	85.1		
					930		80.8	178	87.1		
H	330						29.1	149	74.9	1.62	0.387
		450					39.3	149	79.9		
			570				49.6	149	83.1		
				640			55.4	149	84.4		
					770		67.0	149	86.6		
I							74.2	149	87.6	2.21	0.495
		380					32.9	127	78.3		
			480				41.6	127	81.8		
				540			46.6	127	83.3		
					650		56.6	127	85.6		
L							62.8	127	86.7	2.89	0.603
		330					28.3	111	77.0		
			410				35.9	111	80.7		
				460			40.3	111	82.3		
					570		49.0	111	84.7		
					630	54.5	111	85.9			

MAG 200 P

	VELOCITA' [RPM] ALLE TENSIONI						P [kW]	I [A]	η [%]	ARMATURA	
	260V	330V	400V	440V	520V	570V				L [mH]	R _{115°} [Ω]
A	1320						125.9	532	91.0	0.13	0.030
		1710					162.3	532	92.4		
			2090				194.0	520	93.3		
				2310			209.8	509	93.7		
					2750		237.7	485	94.2		
B	1180						119.1	516	88.8	0.16	0.042
		1530					150.9	503	90.8		
			1880				180.5	490	92.1		
				2080			196.1	481	92.7		
					2490		224.5	462	93.4		
C	960						98.2	429	88.0	0.24	0.056
		1250					125.8	423	90.2		
			1530				151.8	414	91.6		
				1700			165.8	409	92.2		
					2030		192.4	397	93.1		
D	850						87.3	390	86.1	0.29	0.074
		1120					112.7	385	88.7		
			1380				136.9	378	90.4		
				1530			150.1	374	91.1		
					1840		175.3	366	92.2		
E	660						64.7	297	83.9	0.46	0.117
		860					84.6	295	86.9		
			1070				103.9	292	88.9		
				1190			114.6	290	89.8		
F	460						45.6	224	78.2	0.82	0.219
		610					61.0	224	82.4		
			770				76.3	224	85.2		
				860			84.8	223	86.4		
					1030		101.5	221	88.2		
G	350						34.5	178	74.4	1.29	0.331
		470					46.7	178	79.4		
			600				59.0	178	82.7		
				670			66.0	178	84.1		
					810		79.7	178	86.3		
H							88.0	177	87.4	1.85	0.419
		390					38.3	148	78.5		
			490				48.5	148	81.9		
				550			54.3	148	83.4		
					670		65.9	148	85.7		
I							73.1	148	86.8	2.52	0.536
		330					32.0	126	76.8		
			410				40.6	126	80.5		
				470			45.6	126	82.1		
					570		55.5	126	84.6		
L							61.7	126	85.8	3.29	0.653
		330					28.3	111	77.0		
			410				35.9	111	80.7		
				460			40.3	111	82.3		
					490		48.0	110	83.7		
					550	53.5	110	85.0			

NOTE:

- Avvolgimenti compensati
- I dati riportati fanno riferimento a motori:
 - con ventilazione assistita adossata PVA
 - in servizio continuo CEI S1
 - con alimentazione con fattore di forma = 1
 - con temperatura massima ambiente 40 °C
 - con altitudine s.l.m. max 1000 m

Dimensioni d'ingombro

Overall dimensions

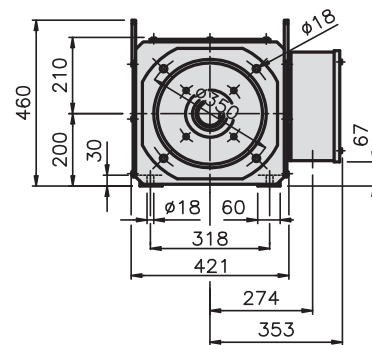
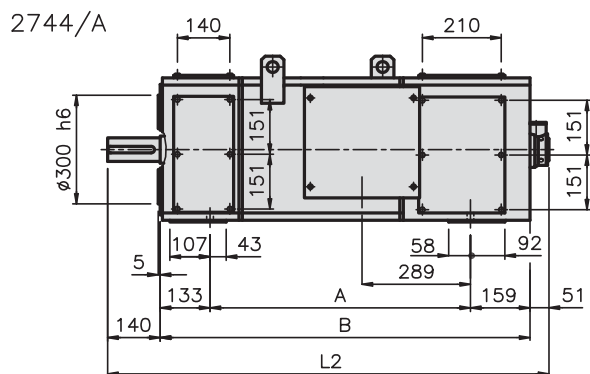
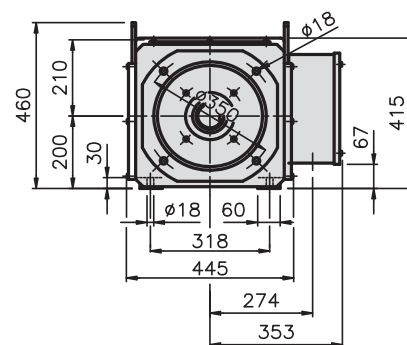
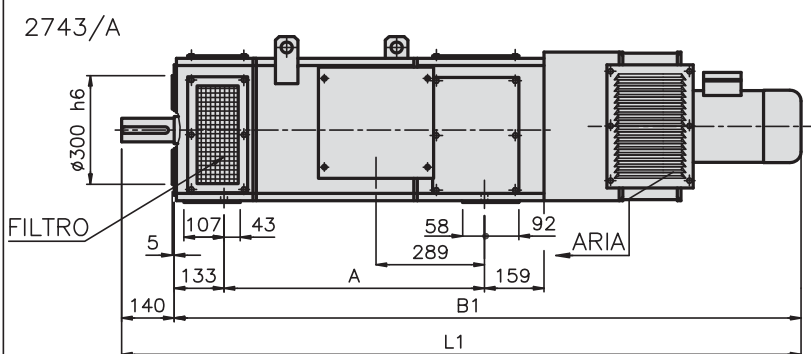
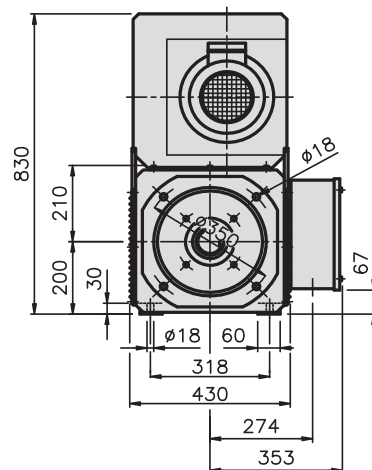
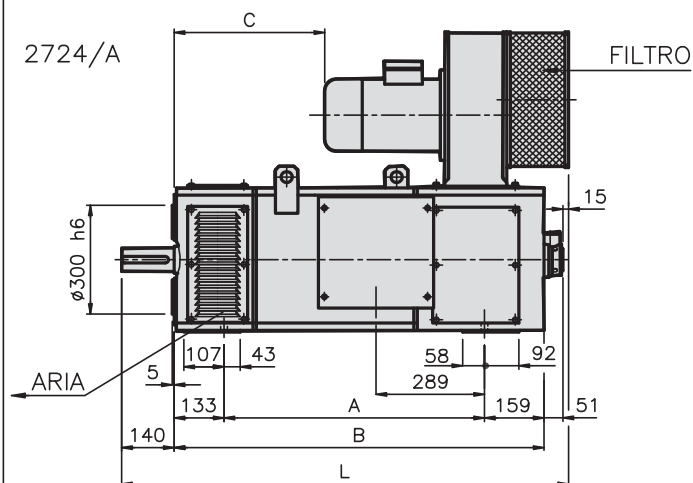

Tipo Type	Ingombri massimi / Max overall							
	A	B	B1	C	L	L1	L2	
MM200 MAG200	S	644	936	1621	352	1142	1761	1127
	M	694	986	1671	402	1192	1811	1177
	L	744	1036	1721	452	1242	1861	1227
	P	794	1086	1771	502	1292	1911	1277

ESTREMITA' ASSE

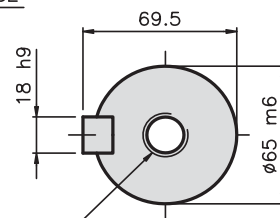

CENTRO M20 UNI 9321